

# Alpha series - Front end cylinder with outer cover



FC A169-5-06230-000-K0343

Item no.  
Tipping weight

70526490  
45 - 57 ton

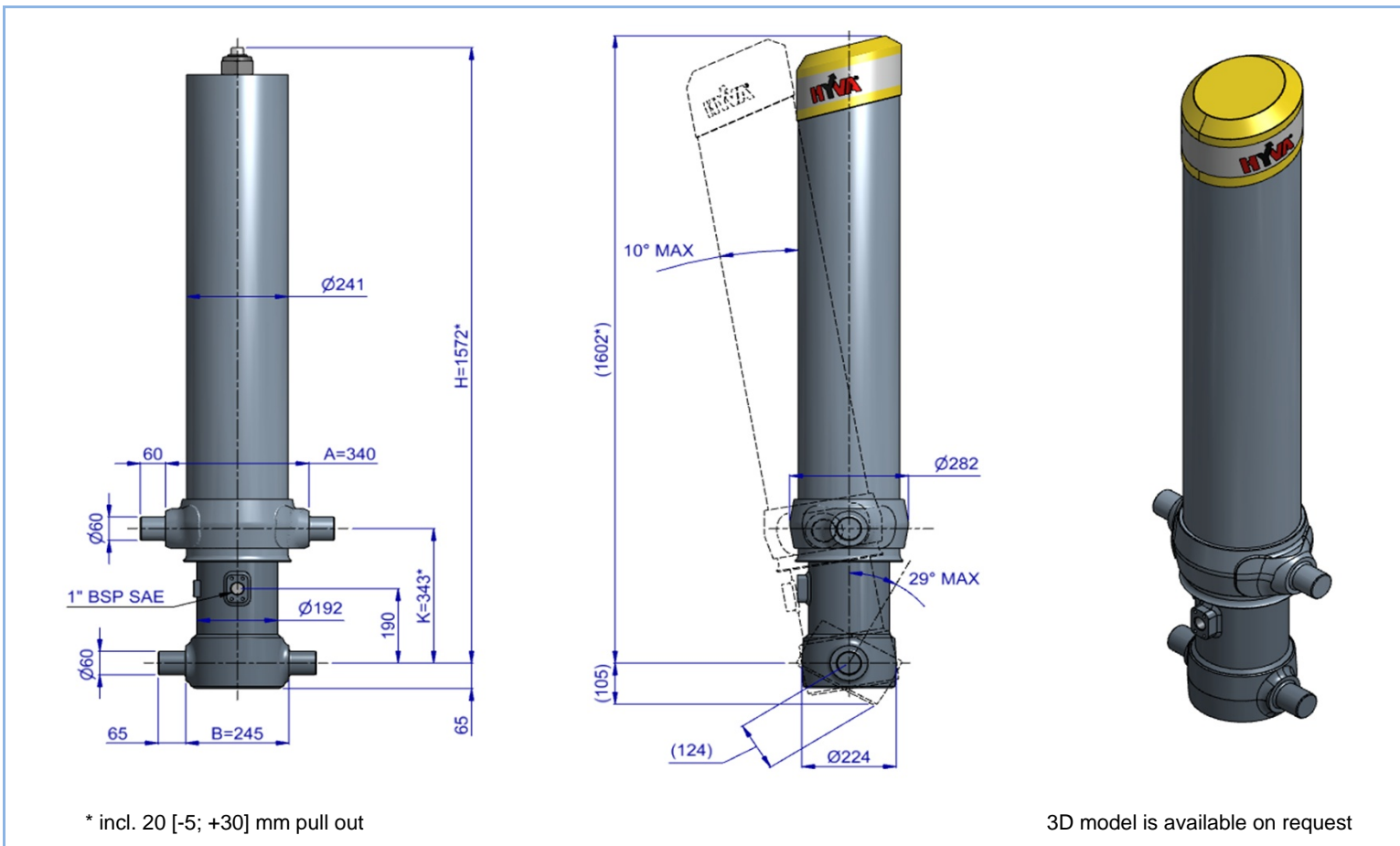

## Specifications

Max. working pressure	250 bar	Max. pump flow (with KO)	190 L/min	Resulting tipping time (with KO)	27 sec
Weight	295 kg	Max. pump flow (without KO)	137 L/min	Resulting tipping time (without KO)	38 sec
Working volume	86 L			Allowable lowering time	27 sec
Total volume	93 L				
Max. cyl. load (start tipping)	245 kN				

KO: Hyva pneumatic knock off

Extension	1	2	3	4	5	6	7	Total
Effective diameter [mm]	169	149	129	110	91			
Stroke* [mm]	1230	1250	1250	1250	1250			6230

## Technical notes

- This cylinder is a lifting device only. It should not be used as a structural member and should not be subjected to side loads.
- When the cylinder is mounted at an angle, the maximum tipping weight could be reduced.
- Maximum backwards angle of rotation during operation is 29 deg.
- Working pressure depends on the application, but must never exceed the maximum working pressure stated.
- Working temperature range is between -40°C and +80°C.
- Maximum duration of extension is 0.5 hours (excluding hard chromed stages).
- Cylinder is painted black (RAL9005) with a thickness conforming to the 480 hours neutral salt spray test as per ISO 9227 (ISO 10289, rating 9).

## Related documentation

Bracket options: 015BRA10 & 015BRA12

Mounting instructions: CYL-0030

Oil specifications: OIL-0011

## Tipping weight

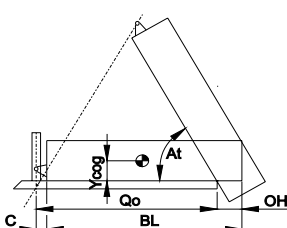

BL	body length
OH	rear overhang
Ycog	vert. pos. centre of gravity
Qo	pivot length
C	bracket length
At	tipping angle stroke* x 60 / Qo

	BL	8300	800	7850	800	7400	800
OH	200	500	800	200	500	800	200
At	44	46	48	47	49	51	50
Ycog							
Qo	600	45	49	53	47	51	56
C	900	48	52	57	51		49
At	1200	51					54

Tipping weight at maximum pressure of 250 bar for a vertically mounted cylinder and C is 229 mm

For detailed tipping calculations please refer to: <https://tipper.hyva.com>

# Alpha series - Front end cylinder with outer cover



FC A169-5-06230-000-K0343

Item no.

70526490

Pos.	Part no.	Description	Qty.
C01	71839030	DUST COVER FC LOW 15-241	1
C02	71709480	COVER 241-1245 PIN60 FIXED MK2	1
C03	01702956 K	WASHER M48 DIN 125B ZP	1
C04	01702907 K	TOPNUT NYLOC M48x3 DIN 985 ZP	1
P01	74402441	PISTON FL2 S 091-1445-HC	1
P02	71853091 K	SLIDER FL 091 (2 X 1/2) A22	1
P03	71851091 K	OUTER STOPRING FL 091 A22	1
P04	71822091	BOTTOM PLATE PISTON 091	1
P05	01745012 K	CIRCLIP 82 DIN 472 (87.5x2.5)	1
P06	71870215 K	O-RING PISTON BOTTOM 091	1
P07	71848200	PISTON HEAD FL 091 MK2	1
P08	01226430 K	O-RING 72.62 X 3.53 MM	1

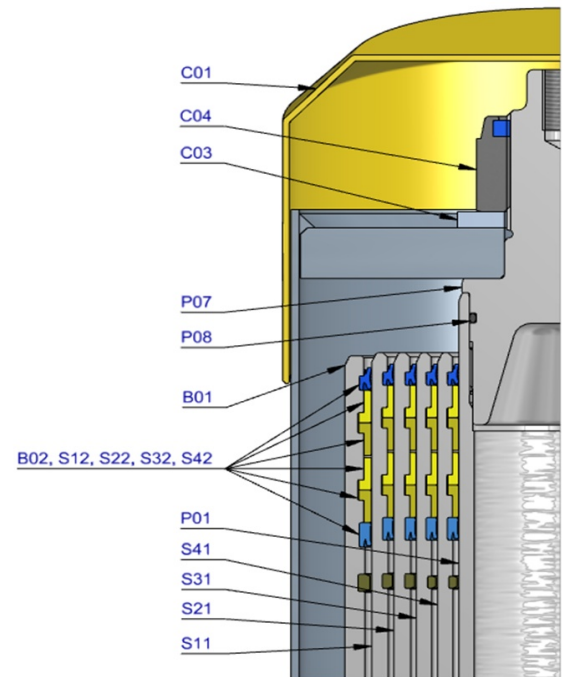

S41	74603440	STAGE FL2 110-1440	1
S42	71802110 K	PACKSET FL 110	1
S43	71853110 K	SLIDER FL 110 (2 X 1/2) A22	1
S44	71851110 K	OUTER STOPRING FL 110 A22	1
S45	71852110 K	LIFTRING FL 110 A22	1

S31	74604440	STAGE FL2 129-1440	1
S32	71802129 K	PACKSET FL 129/HP 129	1
S33	71853129 K	SLIDER FL 129 (2 X 1/2) A22	1
S34	71851129 K	OUTER STOPRING FL 129 A22	1
S35	71852129 K	LIFTRING FL 129 A22	1

S21	74605440	STAGE FL2 149-1440	1
S22	71802149 K	PACKSET FL 149/HP 150	1
S23	71807151 K	SLIDER FL 149 A35	1
S24	71851149 K	OUTER STOPRING FL 149 A22	1
S25	71852149 K	LIFTRING FL 149 A22	1

S11	74606440	STAGE FL2 169-1440	1
S12	71802169 K	PACKSET FL 169	1
S13	71807171 K	SLIDER FL 169 A35	1
S14	71851169 K	OUTER STOPRING FL 169 A22	1
S15	71813169 K	LIFTRING FL 169x5	1

B01	74507440R1145	BASE FL2 191-1483-4/4BSAE-190-C242	1
B02	71802191 K	PACKSET FL 191	1
B03	71825430	BOTTOM PLATE FL2 191	1
B04	71870040 K	SEAL BOTTOM PLATE FL 191	1
B05	71820195	LOCKING PLATE FL2 191	3
B06	01732055 K	BOLT HEX M8X20X1.25 SET 6PCS	1
B07	01732559 K	WASHER SPRING M8 SET 6PCS	1

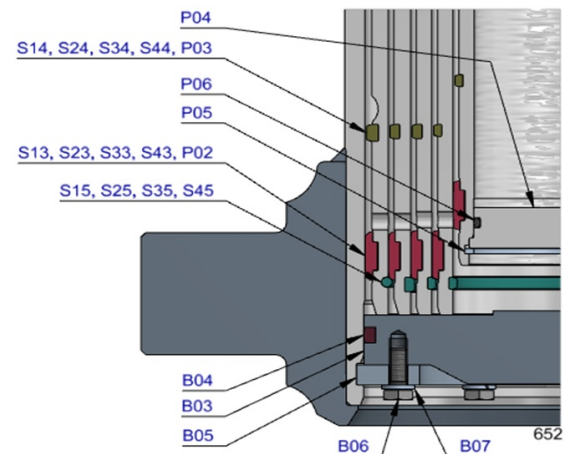
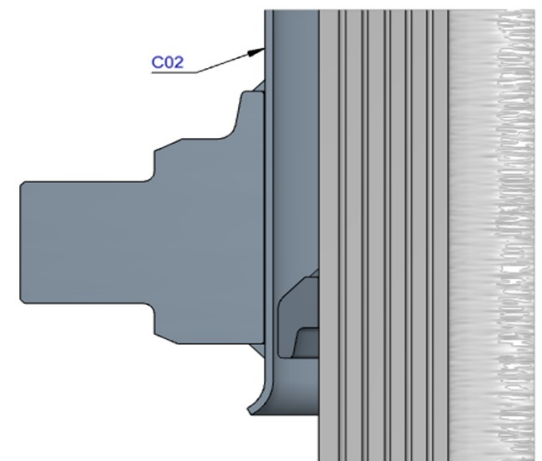

## Seal kit complete

	71908650 K	Consists of all packsets with packset grease and O-rings	
--	------------	--	--

## Notes

The inner, outer stoprings and liftrings are pre-mounted in the grooves on spare stages and pistons. Therefore, when ordering new tubes, it is not required to order stoprings separately.

For repair instructions see: CYL-0040. Serial no. is located on type plate and below type plate support.